

BOEHMLER-PINOCCHIO

VERLAG GEBR. KÖNIG

**CLAUS BOEHMLER ZEIGT:**

# PINOCCHIO

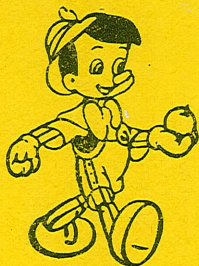

**EIN LINEARES PROGRAMM  
A LINEAR PROGRAM**

**CLAUS BOEHMLER ZEIGT:**

# PINOCCHIO

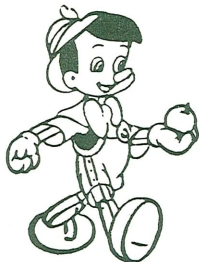

**EIN LINEARES PROGRAMM  
A LINEAR PROGRAM**

© 1969 VERLAG GEBR. KÖNIG, KÖLN-NEW YORK

ALLE RECHTE, AUCH DIE DES AUSZUGSWEISEN NACHDRUCKS UND DER PHOTOMECHANISCHEN WIEDERGABE VORBEHALTEN.  
DRUCK: OFFSETDRUCKEREI J. HARRER, KÖLN, NACH ORIGINALZEICHNUNGEN AUF FILM UNTER VERWENDUNG DES STEMPELS PINOCCHIO  
DER WALT DISNEY PRODUCTIONS. 25 EXEMPLARE WURDEN ALS VORZUGSAUSGABE VERSCHENKT.

WO KOMMST DU HER ?  
WHERE DO YOU COME FROM ?

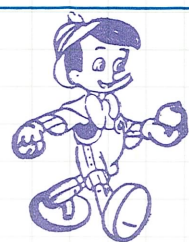
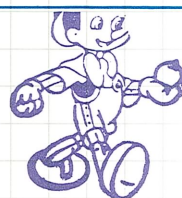
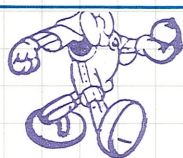

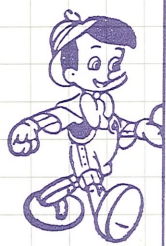

WOHIN GEHST DU ?

WHERE DO YOU GO ?

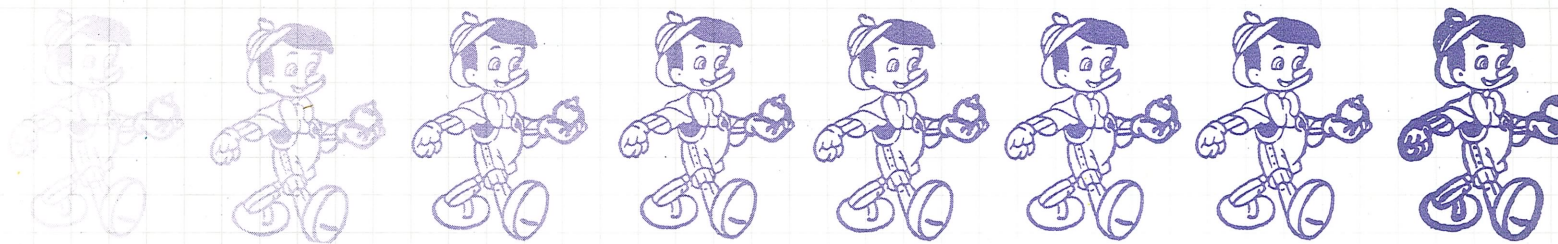

A →

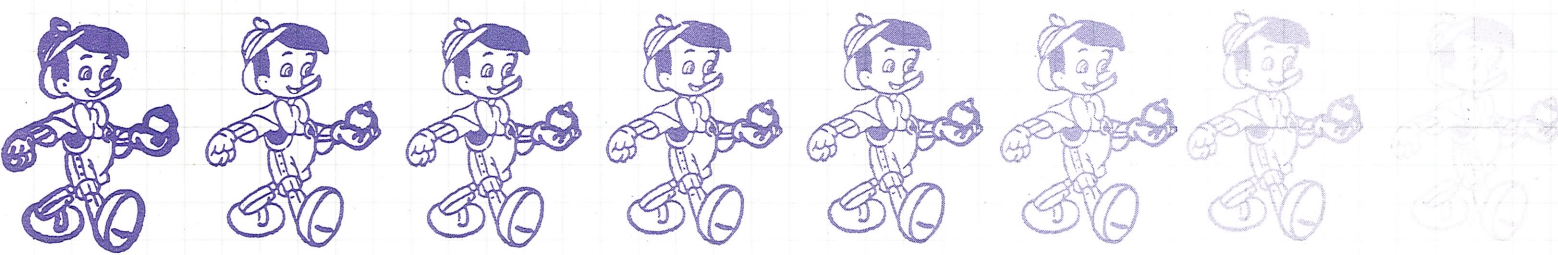

B →

A = Aufblenden - to fade in  
B = Abblenden - to fade out

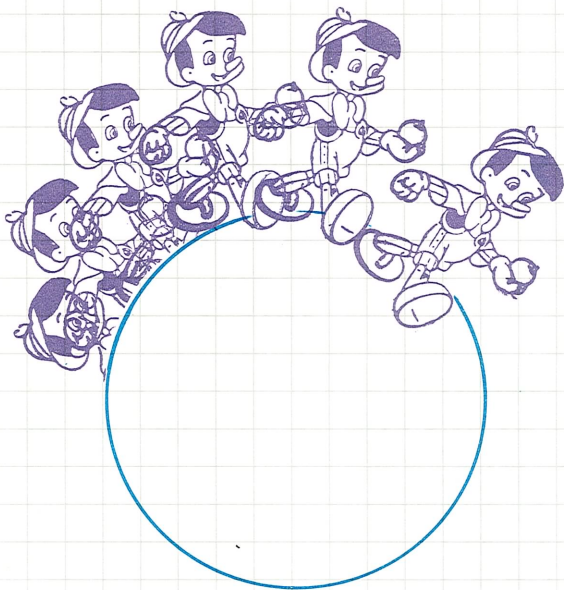

ERDE  
the earth

in Bewegung - in motion

← — Bezugskörper - point of relation

*in Ruhe still background*  
H I N T E R G R U N D

H I N T E R G R U N D

H I N T E R G R U N D

H I N T E R G R U N D

*fig. in motion → in Bewegung*

H I N T E R G R U N D

← in Bewegung  
pan background

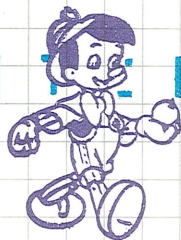

H I N T E R G R U N D

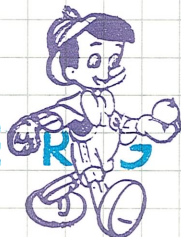

H I N T E R G R U N D



H I N T E R G R U N D

fig. in Ruhe - unmoved



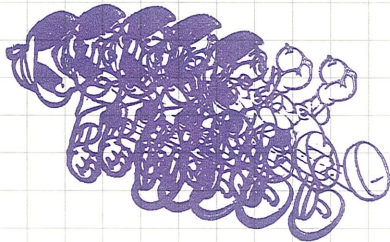
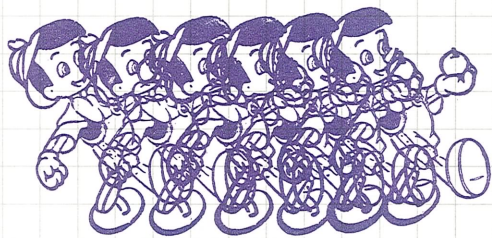

*Reihung - repetition in a row*

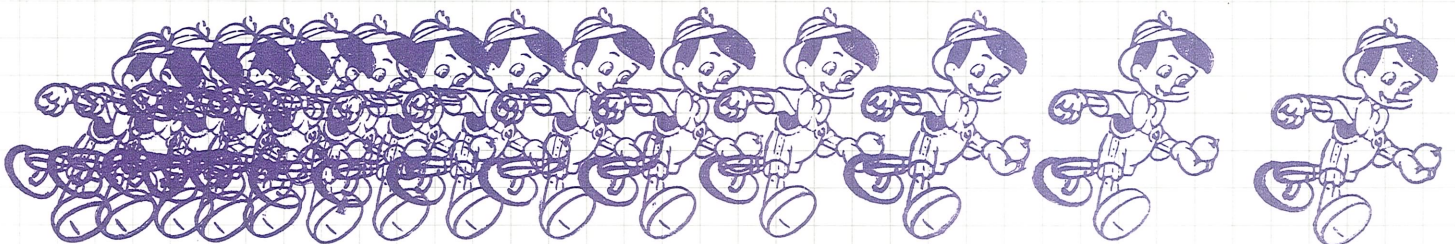
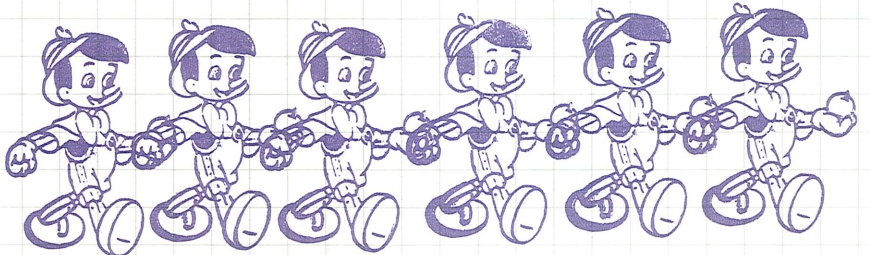
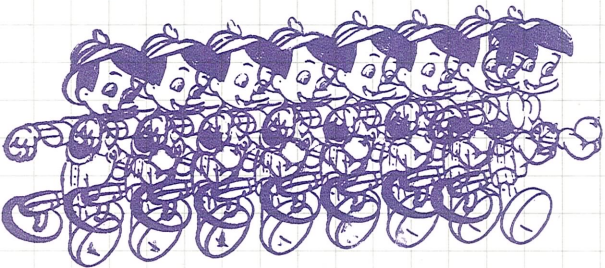

# PINOCCHIO - the cute type

Kanon - basic construction pattern

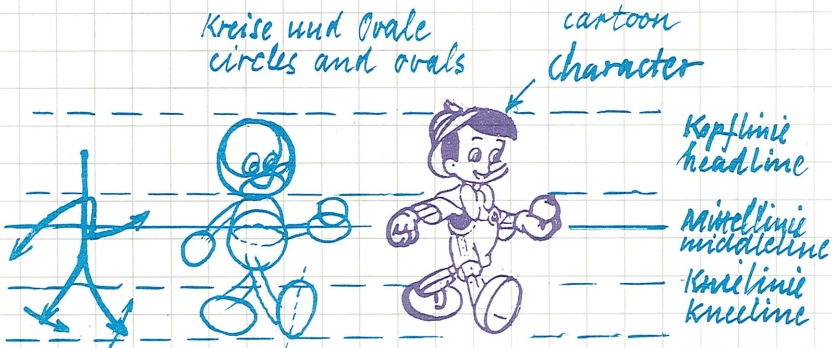

Stempel  
Stamp

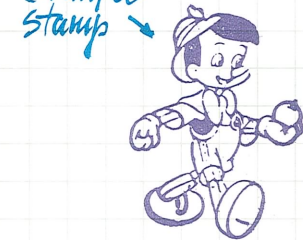

Spiegelung  
reflection

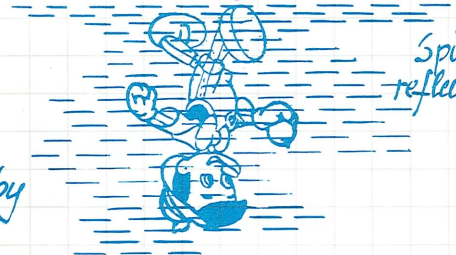

„Kindchenschema“: the proportions are similar to those of a baby

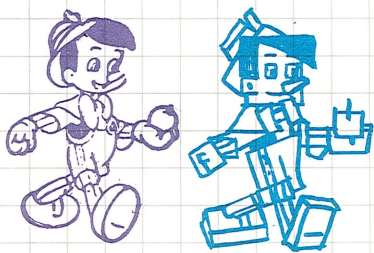

gebogene Linien - ähnlich - geknickte Linien  
curved lines - similar - angular lines

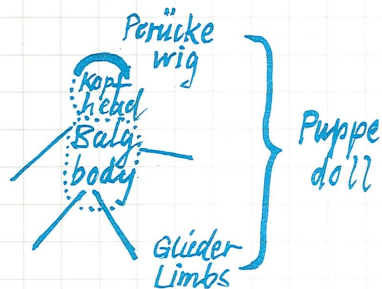

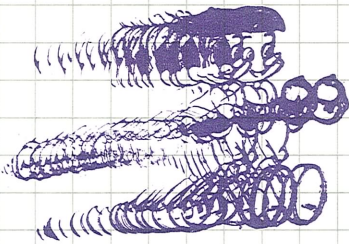

*schnell - speedy*

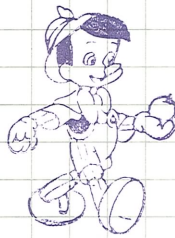

*beleuchtet - illuminated*

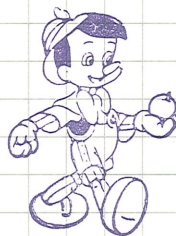

*beschattet - shaded*

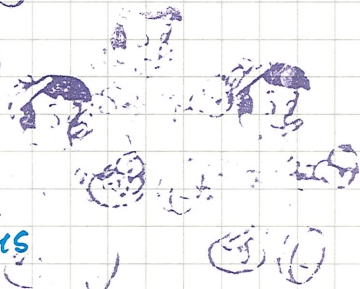

*scharf - unscharf*  
*sharp - out of focus*



ganz  
total



halb  
halb



teilweise  
partial

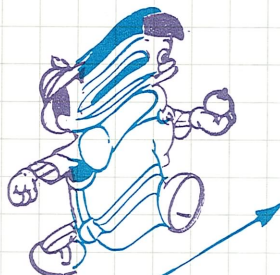

Dehnung

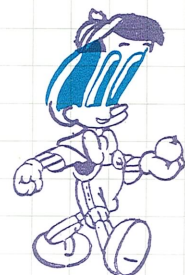

stretch

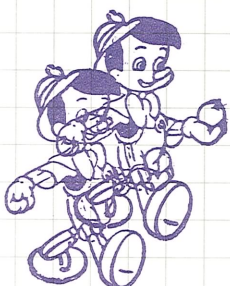

transparent

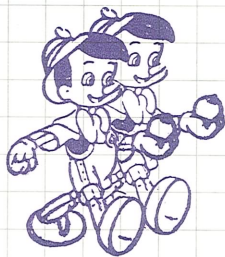

Spalt  
opacime

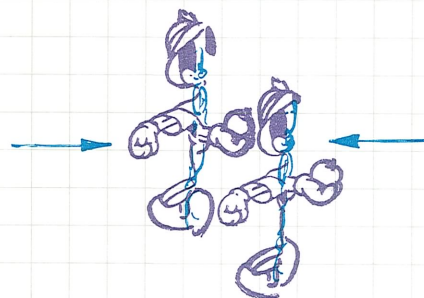

Stauchung



squash

Farbmuster colormodel

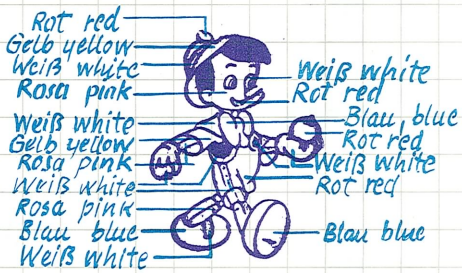

einfarbig

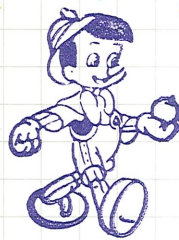

of one color

vierfarbig



of four colors

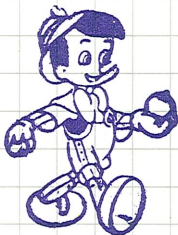

Positiv



Negativ

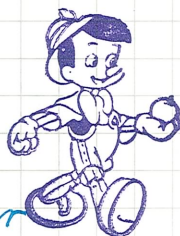

linear



flächig

plane

räumlich spatial

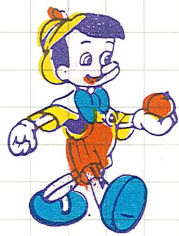

ablösen loslösen  
take off

HUT



hat

FLIEGE



fly  
shirt

HEMD



apple

APFEL



gloves

HAND-  
SCHUHE



shorts

HOSE



shoes

SCHUHE



clothing

BEKLEIDUNG



# Teile - parts

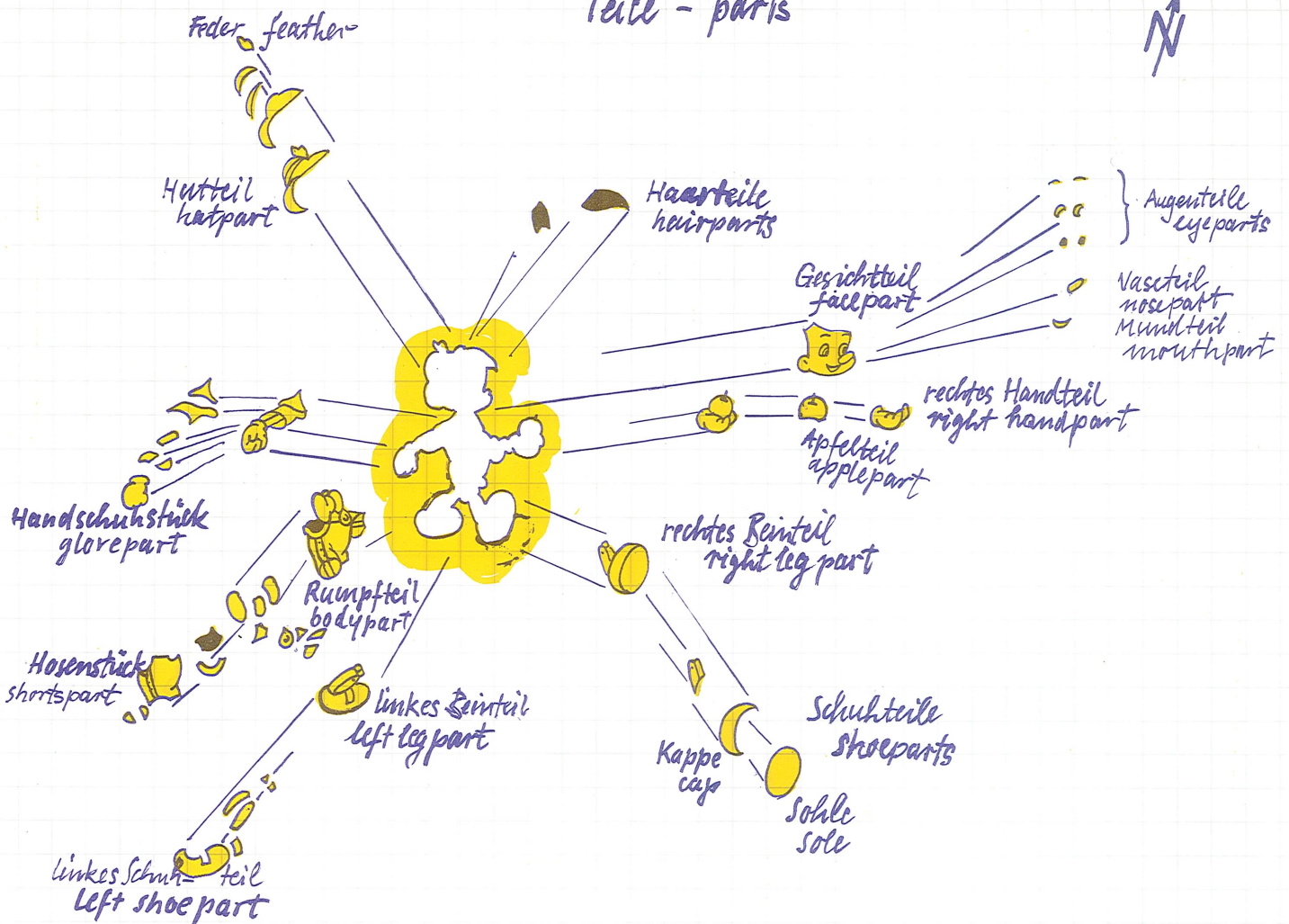



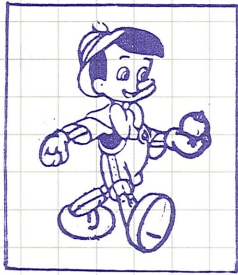

innerhalb  
inside

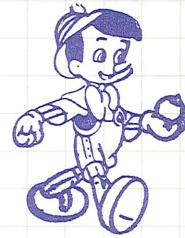
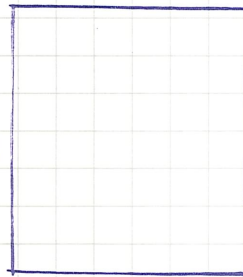
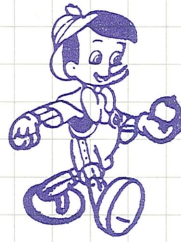

außerhalb  
outside



sehen  
see



sprechen  
talk



hören  
listen



riechen  
smell



denken  
think

tasten  
begreifen  
touch  
grasp



gehen, weiterkommen  
walk

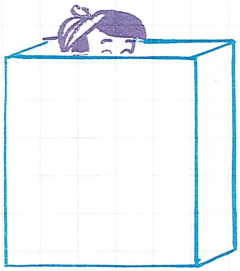

*in  
inside*

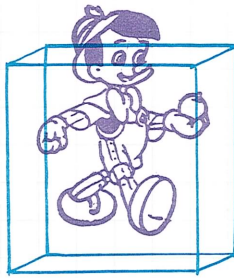

?

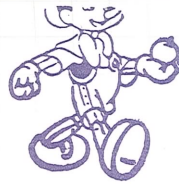

*über  
above*

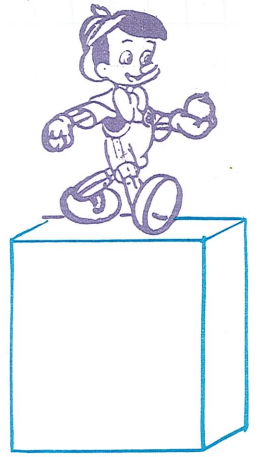

*auf  
on*

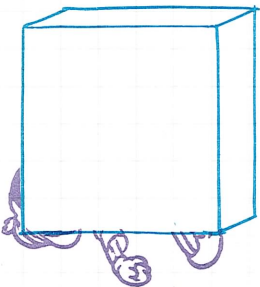

*unter  
underneath*

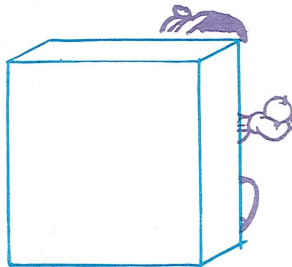

*hinter  
behind*

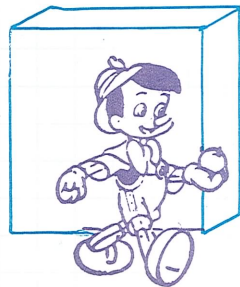

*vor  
in front*

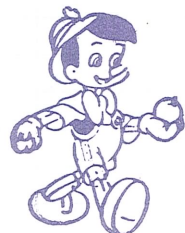

*neben  
beside*

Eine kleine Melodie (7-15 Takte) 8 sec.  
a minor melody (7-15 bars) 8 sec.

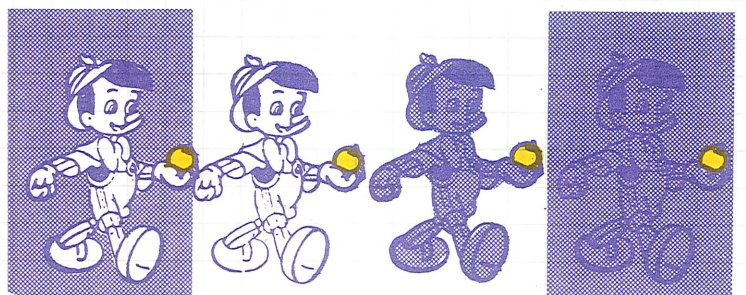
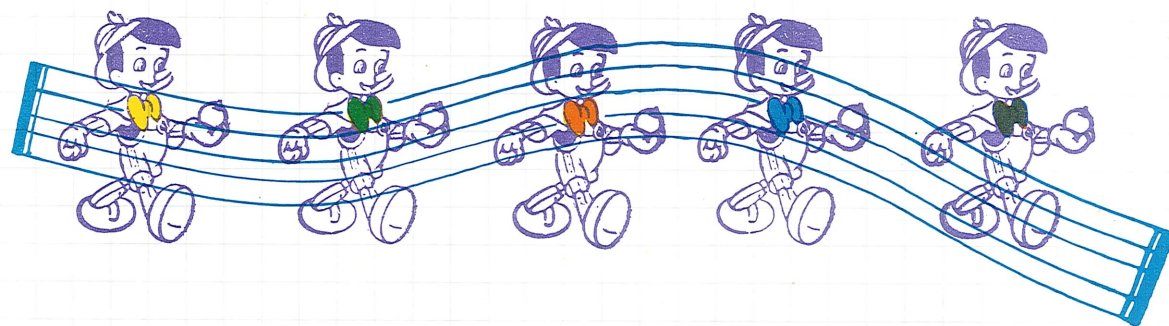

1 2 3 4

4/4

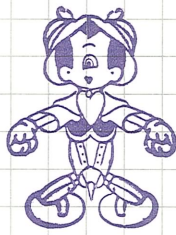
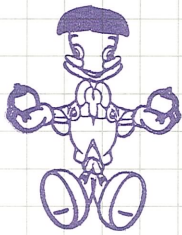

Symmetrie  
Symmetry (axial)  
BALANCE

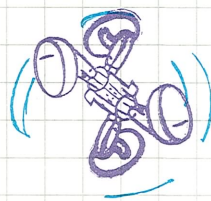
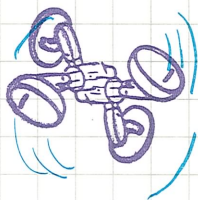
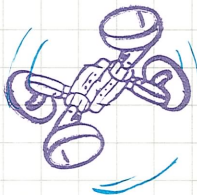
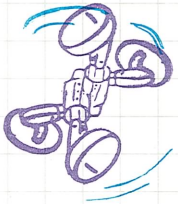

Rotation

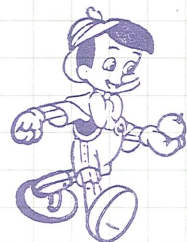
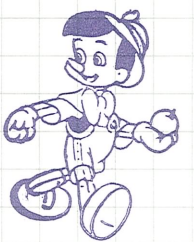
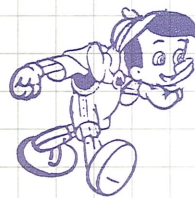
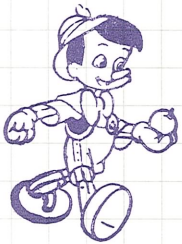
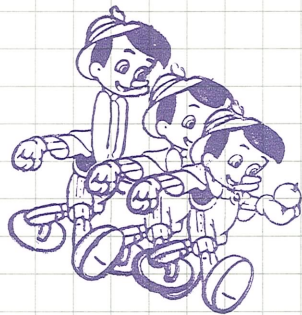

M 1:1

M 2:1

M 4:1

M 1:0.5

Wachsen  
growing

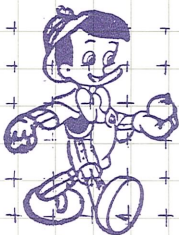

original

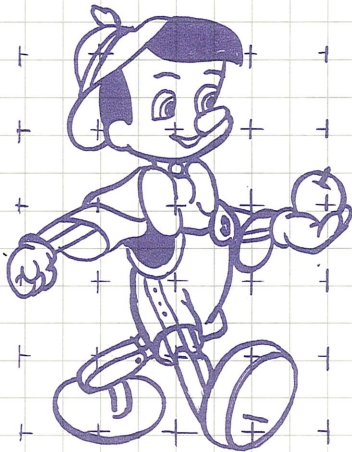

< vergrößert  
enlarged

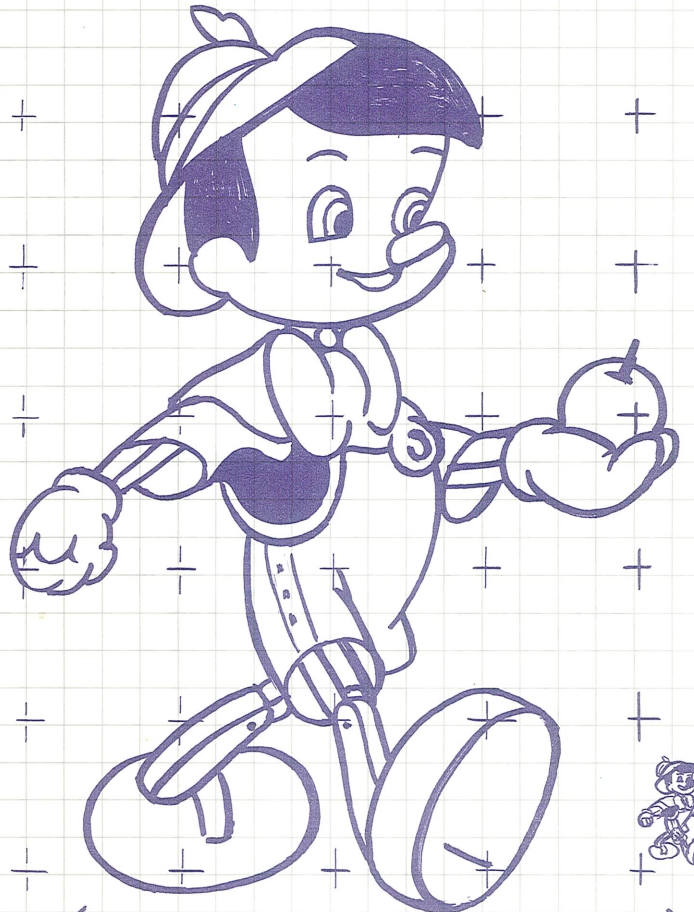

<



>

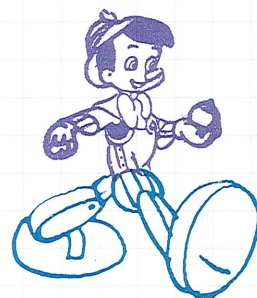
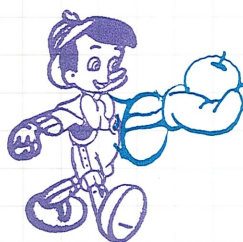
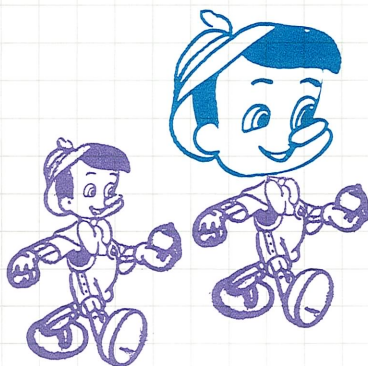
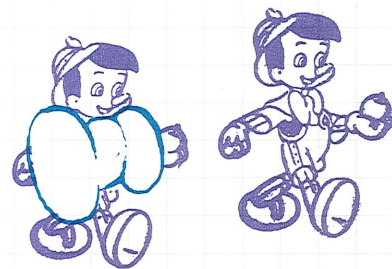
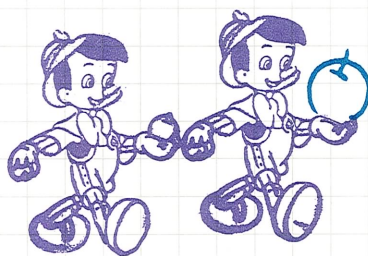

Returning  
accent, emphasis

dominance and subordination

die „Nachfahrende Linie“

Start

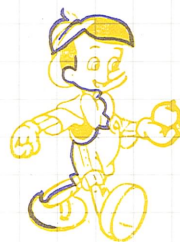
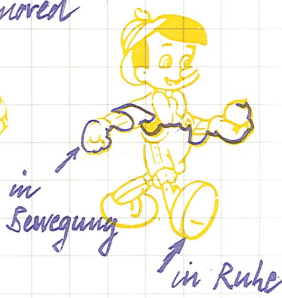
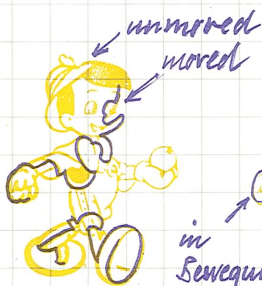
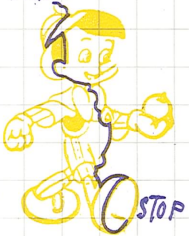

Kreuzung  
crossing

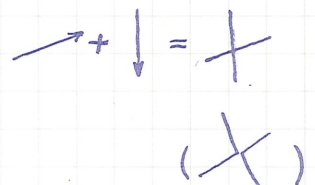

to trace and retrace



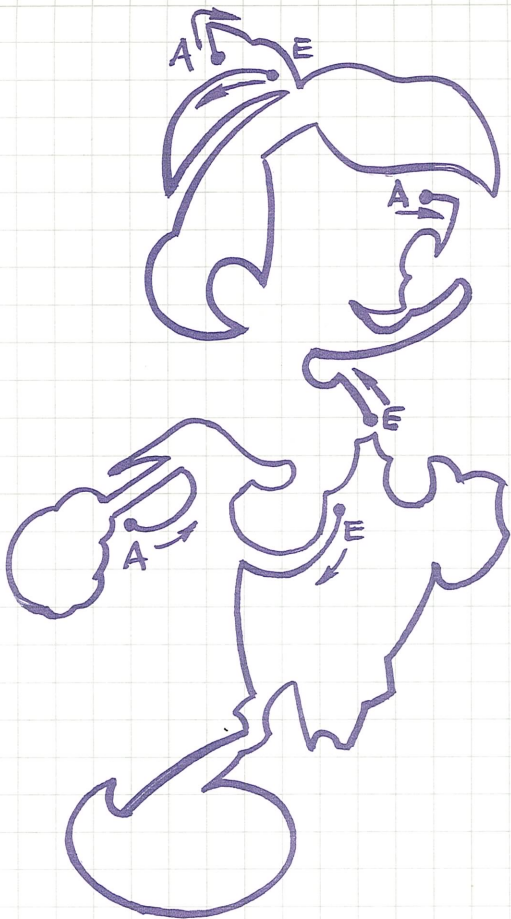

Aktive Linien  
Erscheinen lassen:  
Von Bezugspunkt A ausgehende Bewegung

active lines:  
Appearance:  
movement starting at A, the point of relation

# Informationsfelder - information areas

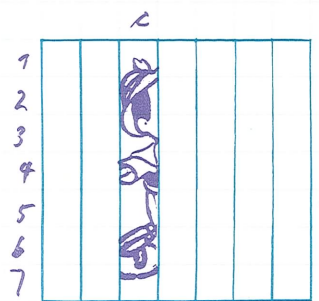
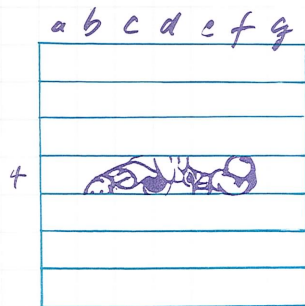
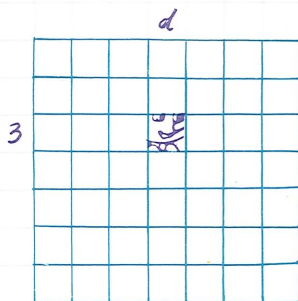

horizontal ↔

vertical ↓

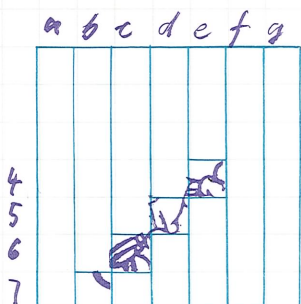

diagonal ↗

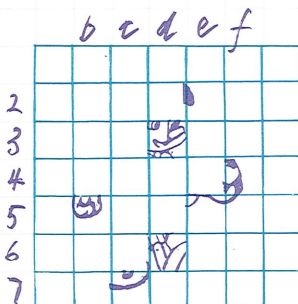

unregelmäßig  
unregular



Eindrücke  
impressions



sich  
to



etwas  
gather



in  
impressions



einigen  
step



Schritten  
by



einprägen  
step

Aufgliederung im Raum  
shifted lines and planes

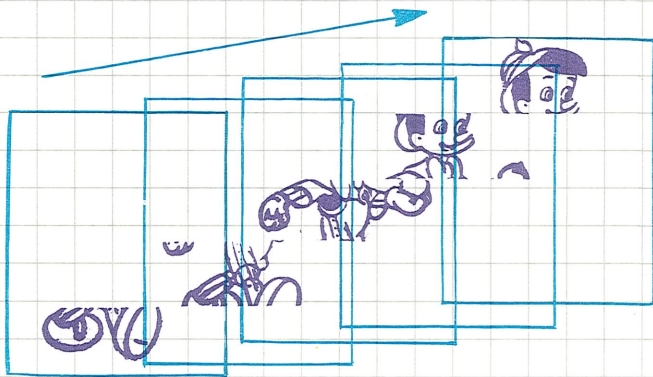

multiplane

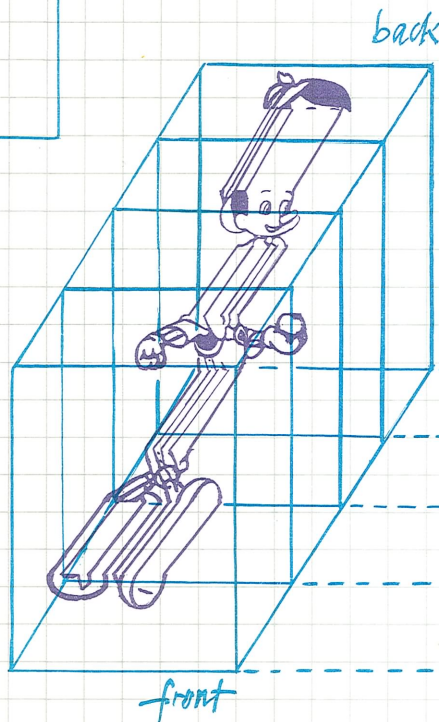

- 5. Zeichenebene
- 4. "
- 3. "
- 2. "
- 1. drawing-plane

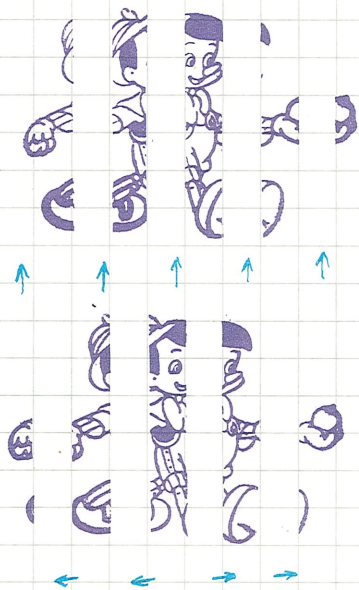
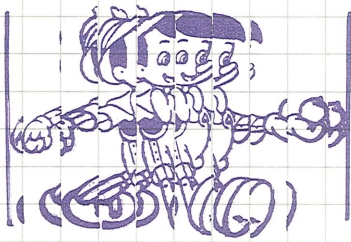

mehrere in Einem  
more than one in one

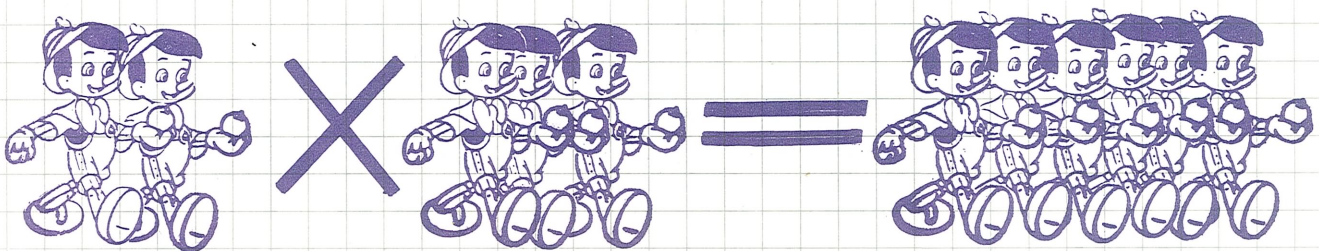
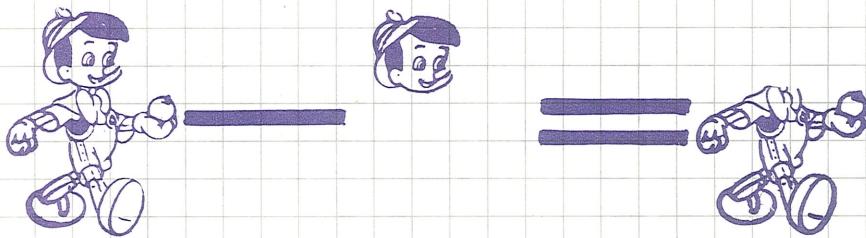
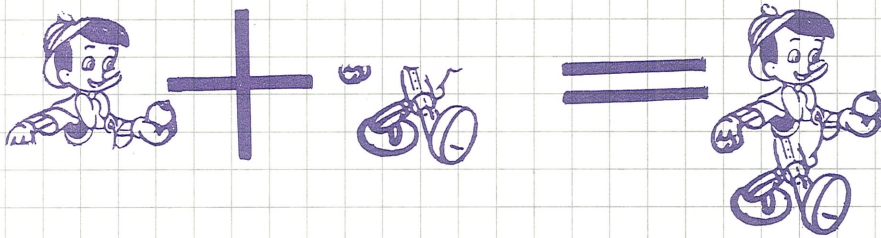

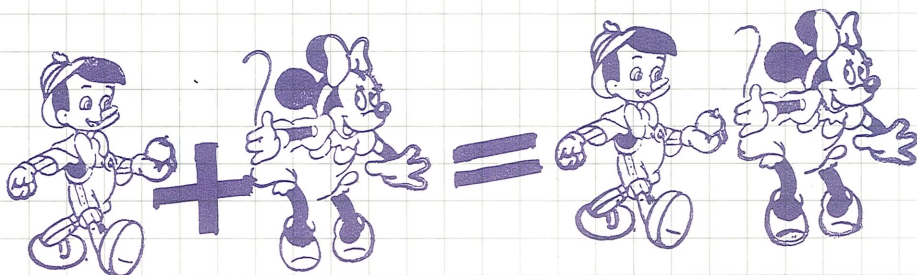
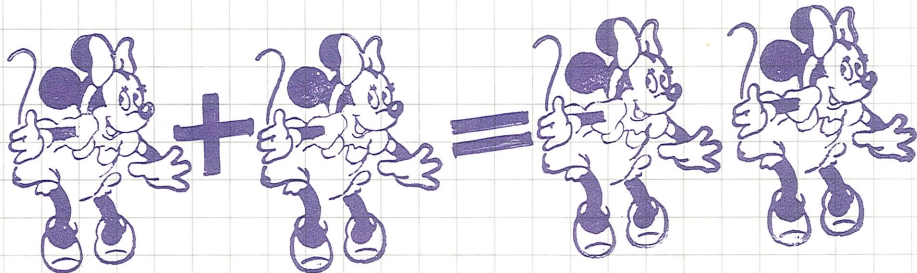
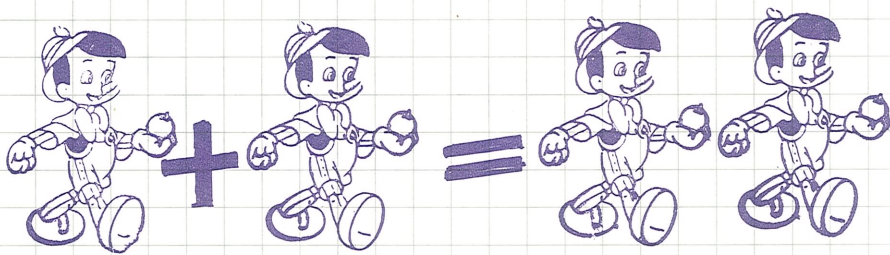

aber... →  
but...

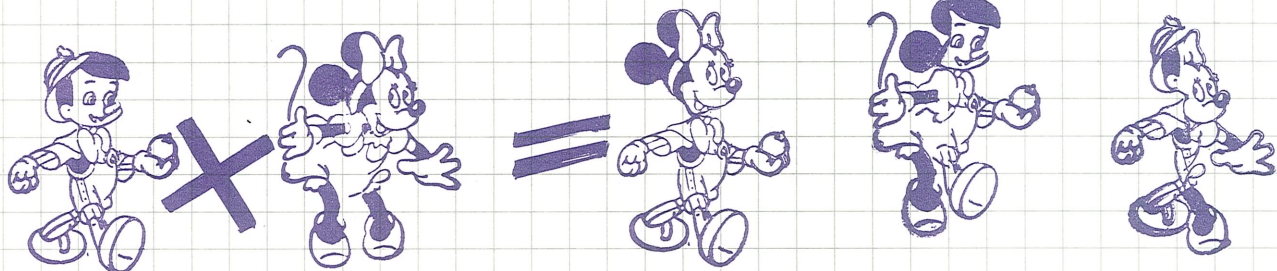
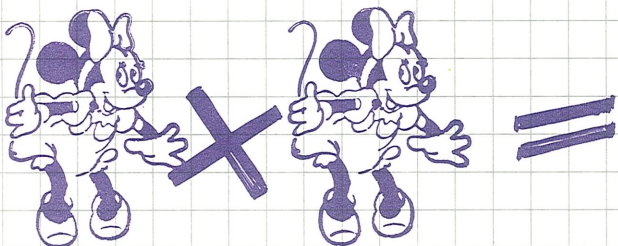
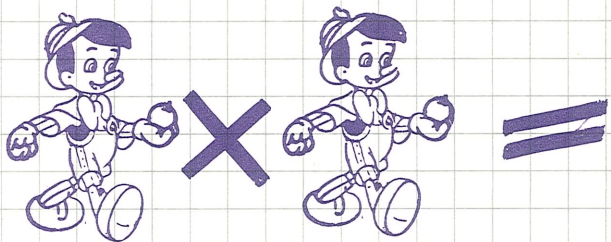

# Vertraulich

♂	×	♂	=	○	(zero)
♀	×	♀	=	○	(zero)
♂	×	♀	=	♂	oder ♀ (♀)

USW:  
2, 5, 2.

neue Möglichkeiten, Figuren, Mischungen  
new possibilities, figures, mixtures





eye-action!

mouth action!

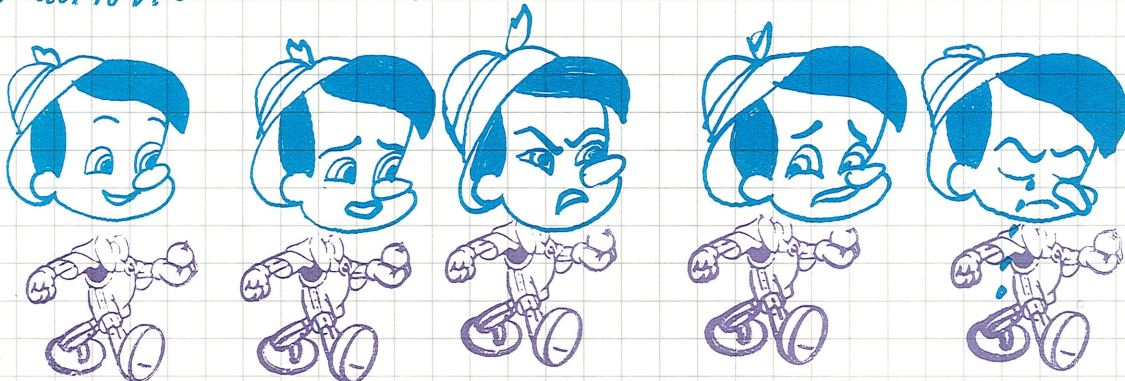

Gesichtsdruck (Augen - Mund)

facial expressions



